

D-43 PN 16



Barak Pro Combination Air Valve

Description

The D-43 series Combination Air Valve has the features of both an air release valve and an air & vacuum valve.

The air release component is designed to automatically release small pockets of air to the atmosphere as they accumulate along a pipeline or piping system when it is full and operating under pressure.

The air & vacuum component is designed to automatically discharge or admit large volumes of air during the filling or draining of a pipeline or piping system. This valve will open to relieve negative pressures whenever water column separation occurs.

Applications

- Pump stations: after the pump and after the check valve.
- Downstream (after) and upstream (before) of shut-off valves.
- After deep-well pumps.
- On long constant-sloped pipeline segments.
- At peaks along the pipeline and at peaks relative to hydraulic gradient.
- At end lines.
- Before water meters.
- On strainers and filters.

Operation

The air & vacuum component, with the large orifice, discharges air at high flow rates during the filling of the system and admits air into the system at high flow rates during its drainage and at water column separation.

High velocity air will not blow the float shut. Water will lift the float, which seals the valve.

At any time during system operation, should internal pressure of the system fall below atmospheric pressure, air will enter the system.

The smooth discharge of air reduces pressure surges and other destructive phenomena.

The intake of air in response to negative pressure protects the system from destructive vacuum conditions and prevents damage caused by water column separation. Air entry is essential to efficiently drain the system.

The air release component releases entrapped air in pressurized systems.

Without air valves, pockets of accumulated air may cause the following hydraulic disturbances:

- Restriction of effective flow due to a reduction of the flow area. In extreme cases this will cause complete flow stoppage.
- Obstruction of efficient hydraulic transmission due to air flow disturbances.

- Acceleration of cavitation damages.
- Increase in pressure transients and surges.
- Internal corrosion of pipes, fittings and accessories.
- Dangerous high-energy bursts of compressed air.
- Inaccuracies in flow metering.

As the system fills and is pressurized, the combination air valve functions in the following stages:

1. Air in the pipeline is discharged by the air valve.
2. Liquid enters the air valve, lifting the complete float and seal assembly to its sealing position.
3. Entrapped air, which accumulates at peaks and along the system, rises to the top of the air valve, which in turn displaces the liquid in the air valve body.
4. The lower component of the float and seal assembly drops down unsealing the rolling seal, opening the air release orifice and releasing the accumulated air.
5. Liquid enters the air release valve, the lower component of the float and seal assembly rises, pushing the rolling seal to its sealing position.

When internal pressure falls below atmospheric pressure (negative pressure):

1. The complete float and seal assembly will drop down, immediately opening the air & vacuum and air release orifices.
2. Air will enter into the system.

Main Features

- Working pressure range: 0.2 - 16 bar
- Testing pressure: 1.5 times the maximum working pressure of the air valve.
- Maximum working temperature: 60° C.
- Maximum intermittent temperature: 90° C.
- Reliable operation reduces water hammer incidents.
- Dynamic design allows for high capacity air discharge while preventing premature closure.
- Lightweight, small dimensions, simple and reliable structure.
- The discharge outlet enables the connection of a vent hose/pipe.
- The large size of the automatic air release orifice relative to the air valve body:
 - Discharges air at high flow rates.
 - Lessens the danger of its obstruction by debris.
 - Enables the usage of the rolling seal, making it less sensitive to pressure differential than a direct float seal.
- The body is made of high-strength UV protected composite materials and all operating parts are made of specially selected,

corrosion- resistant materials.

- Due to its light weight, the valve may be installed on plastic piping systems, as well as other lightweight piping systems.
- Minimum down-time for maintenance – all operating parts are consolidated into one replaceable cartridge.

Valve Selection

The air valve is available with:

- Size range: 2” threaded male connections, NPT or BSPT.

Options

- The D-43 air valve is available in the following options:

- D-43 reinforced nylon body.
- D-43 ST ST - stainless steel body.

• One-way models

The D-43 series air valve is available as:

- **D-43-V** -With a one-way, out-only attachment, allows air discharge only, prevents air intake (all models).
- **D-43-I** -With a vacuum breaker, in-only attachment, allows air intake only, not allowing air discharge
- **D-43-NS** -With a non-slam, discharge-throttling attachment, allows full air intake, throttles air discharge

- Upper Drain Outlet

The D-43 upper drain outlet will drain accumulated water when the air valve is under pressure and sealed. This application is required when impure water accumulates above the sealing mechanism and is not permitted to enter the system when vacuum conditions occur. A drain pipe can be attached to the upper drain outlet to direct the water away from the D-43 air valve.

As standard, the D-43 air valve comes with the upper drain outlet sealed. Optionally, the D-43 can be ordered with the upper drain outlet open and with or without the attached drain pipe. (The upper drain outlet can also be easily drilled open in the field.)

- Male Threaded 2" Inlet

The D-43 air valve is available with a male threaded 2" inlet adaptor in both BSP and NPT.

Upon ordering, please specify: model, size, working pressure, threads standard and type of liquid.

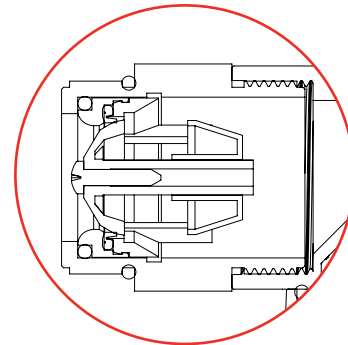

D-43 Non-Slam Single Orifice Add-on Component Data Table

Model	Nominal Size	Discharge orifice	Total NS area	NS orifice	Switching point	Flow at 0.4 bar
D-43 NS	2" (50mm)	37.5 mm	12.6 mm ²	4 mm	Spring loaded normally closed	17.5 m ³ /h

D-43

AIR AND VACUUM FLOW RATE

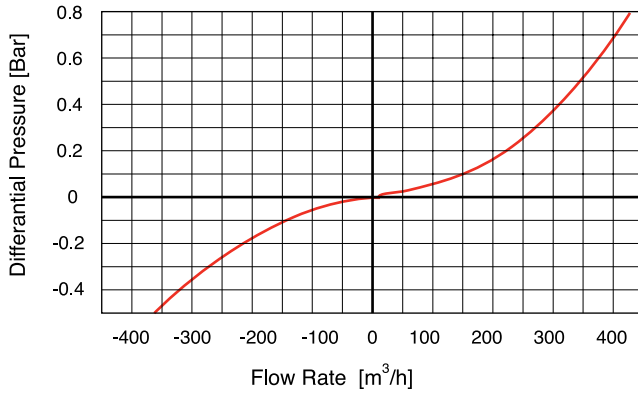

AUTOMATIC AIR RELEASE FLOW RATE

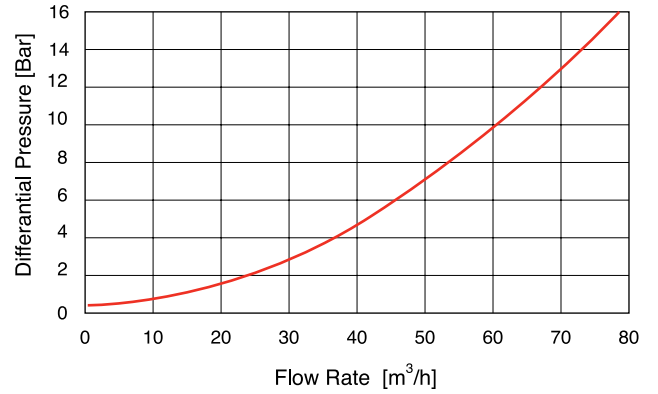

D-43 V

AIR DISCHARGE FLOW RATE

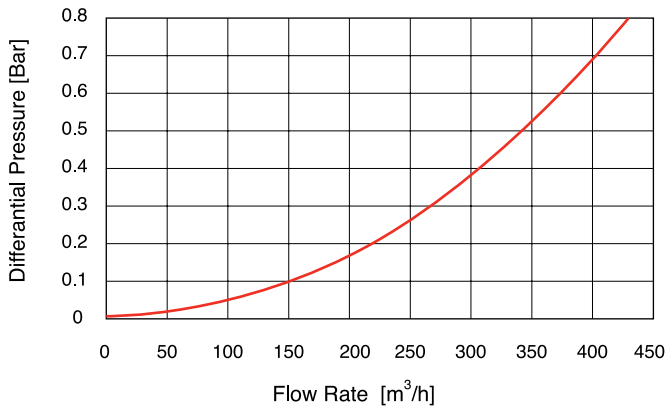

D-43 NS

AIR AND VACUUM FLOW RATE

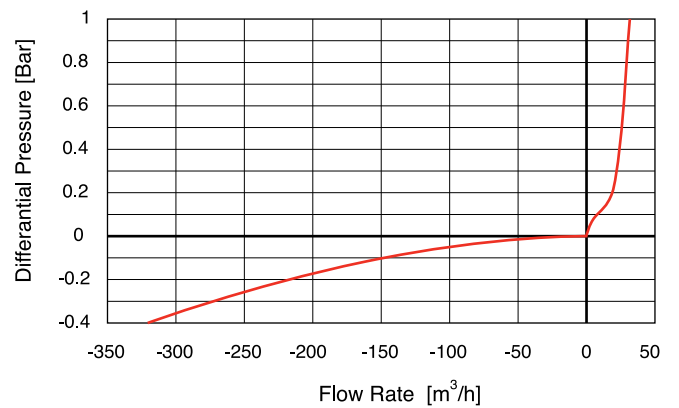

D-43 I

AIR INTAKE FLOW RATE

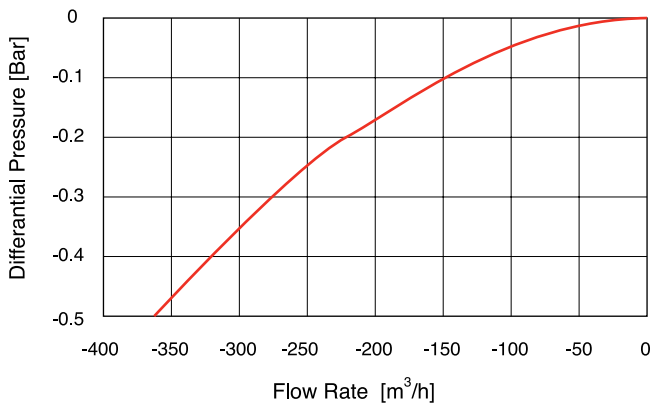

DIMENSIONS AND WEIGHT

Size	Dimensions mm		Connections C	Weight Kg.	Orifice Area mm ²	
	A	B			A / V	Auto.
2" (50mm) Threaded	85	244.5	1½" BSP Female	0.45	900	10

PARTS LIST AND SPECIFICATION

No.	Part	Material
1.	Discharge Outlet	Polypropylene
2.	O-Ring	BUNA-N
3.	Body	Reinforced Nylon
4.	Float and Seal Assembly	Polypropylene + Acetal + E.P.D.M.
4a.	Air & Vacuum Seal	E.P.D.M.
4b.	Air Release Rolling Seal	E.P.D.M.
5.	Float Lock	Acetal
6.	Upper Drain Outlet	

